

Fact Sheet

# RUSSIAN CO-ORBITAL ANTI-SATELLITE TESTING

December 2024

CONTACT: VICTORIA SAMSON  
VSAMSON@SWFOUND.ORG



SECURE  
WORLD  
FOUNDATION

## SUMMARY

Since 2010, Russia has been testing technologies for RPO in both LEO and GEO that could lead to or support a co-orbital ASAT capability, and some of those efforts have links to a Cold War-era LEO co-orbital ASAT program. Additional evidence suggests Russia may have started a new co-orbital ASAT program called Burevestnik, potentially supported by a surveillance and tracking program called Nivelir. The technologies developed by these programs could also be used for non-aggressive applications, including surveilling and inspecting foreign satellites, and most of the on-orbit RPO activities done to date match these missions. However, Russia has deployed two “sub-satellites” at high velocity, which suggests at least some of their LEO RPO activities are of a weapons nature.

## CO-ORBITAL ASAT PROGRAMS

Co-orbital ASATs place an interceptor into orbit, which then maneuvers to alter its orbit to a trajectory that brings it close to a target. Co-orbital ASATs could maneuver to approach immediately after being placed into orbit or after remaining dormant for an extended period of time. They can try to damage or destroy their target by direct collision at hyper velocities, releasing a cloud of fragments that will collide with the target, using a robotic arm to damage or remove parts of a target satellite, or using electronic warfare or directed energy weapons at close range. Regardless of the technique used, co-orbital ASATs require onboard guidance, navigation, and control systems to identify and track a targeted space object and fine-tune its trajectory for proper interception. During the Cold War, the Soviet Union had multiple efforts to develop, test, and deploy co-orbital ASAT capabilities. Several different concepts for the deployment of co-orbital weapons were considered, including lasers, missile platforms, crewed and uncrewed gunnery platforms, robotic manipulators, particle beams, shotgun-style pellet cannons, and nuclear space mines, but most died on the drawing board.<sup>1</sup>

### IS and IS-M

The first known serious Soviet effort to develop a co-orbital ASAT system was the Istrebitel Sputnikov (IS) or “satellite fighter” system, which was conceived in the late 1950s and began development in the 1960s.<sup>2</sup> After being launched into orbit, the interceptor would separate from the booster, make multiple changes to its orbit so that it passed close to the target object, and then explode to release shrapnel that had an effective range of 50 m. The IS-M was an upgraded version that could attack higher altitude orbits. The IS and IS-M systems were tested in orbit multiple times over three decades, with several actual intercepts against targets between 230 and 1,000 km and the creation of nearly 900 pieces of orbital space debris larger than 10 cm.<sup>3</sup> The targeting and control systems are also known to have been maintained in working condition and have undergone comprehensive upgrades and modernization over the last decade.<sup>4</sup>

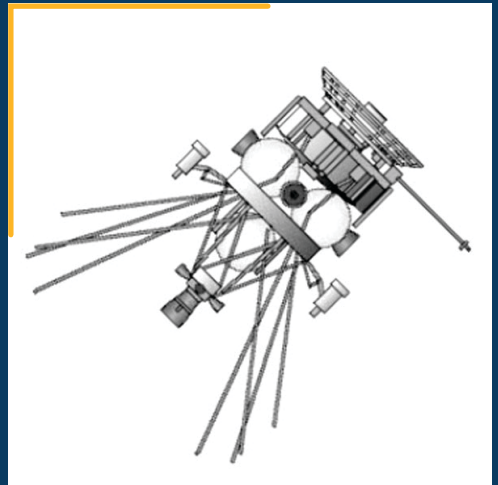

**Istrebitel Sputnikov.**

*Image Credit: Mark Wade*

## Naryad

Towards the end of the Cold War, the Soviet Union began the development of a new and more capable co-orbital system known as Naryad-V. The Naryad-V used a silo-based solid-fuel rocket launch vehicle paired with a new and very capable liquid-fuel upper stage that allowed the system to target an extremely wide range of orbits with rapid launches of large numbers at once.<sup>5</sup> The Naryad launch vehicle had two sub-orbital flight tests in November 1990 and December 1991.<sup>6</sup> A third orbital flight test was conducted in December, with Rocket booster delivering Radio ROSTO amateur radio satellite into a 1,900 by 2,145 km orbit.<sup>7</sup> It is rumored that the launch had a second payload, which may have been the Naryad interceptor, that fragmented shortly after launch. 27 pieces of orbital space debris were cataloged, of which 24 are still on orbit.

## BUREVESTNIK AND POTENTIAL NEW CO-ORBITAL ASAT TESTING

Since 2010, Russian satellites have conducted several robotic RPO with rocket bodies and other satellites, including non-Russian satellites, in both LEO and GEO, that could be used for surveillance or intelligence purposes or co-orbital ASATs. On June 23, 2017, Russia launched a “space platform which can carry different variants of payloads” designated Cosmos 2519.<sup>8</sup> On August 23, Russian officials announced that a small satellite designated Cosmos 2521 had separated from Cosmos 2519 and was “intended for the inspection of the condition of a Russian satellite.”<sup>9</sup> Subsequently, Russia reported that the Cosmos 2521 satellite-inspector completed a series of proximity operations experiments and returned to the Cosmos 2519 host satellite on October 26.<sup>10</sup> On October 30, Russia announced that another small satellite, Cosmos 2523, separated from Cosmos 2521 to inspect another satellite<sup>11</sup> but to date Cosmos 2523 has not approached any other satellites. U.S. officials later stated that the ejection of Cosmos 2523 happened at the “high relative speed of about 250 km/hr.”<sup>12</sup> Comments from senior US military leadership suggest they consider the deployment of Cosmos 2523 to have been an ASAT test, given its relatively large deployment velocity.<sup>13</sup> As of February 2024, Cosmos 2523 remains on orbit.

A similar event happened again in 2020. On November 25, 2019, Russia launched a military payload from Plesetsk (Cosmos 2542) to conduct space surveillance as well as Earth remote sensing.<sup>14</sup> On December 6, Russia announced that Cosmos 2542 released a small subsatellite deemed Cosmos 2543.<sup>15</sup> Cosmos 2543 trailed within 2 km of Cosmos 2542 for three days before it conducted a series of maneuvers to raise its apogee to 590 km by December 16.<sup>16</sup> Subsequent analysis by amateur observers strongly suggests that the purpose of these maneuvers was to place Cosmos 2543 in an orbit where it can observe a classified U.S. intelligence satellite, USA 245.<sup>17</sup> In early June 2020, Cosmos 2543 made multiple maneuvers in order to descend within 60 km of Cosmos 2535. On July 15, a third object (object number 45915) separated from Cosmos 2543 at a relative velocity of about 200 m/s (700 km/h). The United States publicly characterized the release of object 45915 as a test of an anti-satellite weapon.<sup>18</sup>

In addition to these satellite ejections, another RPO may have also been part of a co-orbital ASAT test. Cosmos 2535 and Cosmos 2536 were launched along with two other military payloads in July 2019 into a 97.88° inclination and 612 by 623 km orbit. On August 1, 2019, Russia announced that Cosmos 2535 and Cosmos 2536 would be engaged in satellite inspection and satellite servicing activities,<sup>19</sup> which happened between August 7-19, 2019. Shortly before the RPO, nine debris objects were released in the vicinity of the two satellites, with apogees as high as 1400 km, suggesting a significant energetic event.<sup>20</sup> In early October 2019, several additional debris objects were detected, although it is uncertain which parent object they came from. Cosmos 2535 and Cosmos 2536 continued their RPO activities in December 2019, which resulted in the release of six more debris objects. As of February 2024, 30 cataloged debris objects

have been associated with this launch. <sup>21</sup>

The activities of Cosmos 2519/2521/2523, Cosmos 2542/2543/Object 45915, and Cosmos 2535/2536 may be linked to an active Russian co-orbital ASAT program codenamed Burevestnik (“Petrel”) or project 14K168 that was started in 2011 and is managed by the Central Scientific Research Institute for Chemistry and Mechanics (TsNIIKhM). <sup>22</sup> Burevestnik appears to be an air-launched co-orbital ASAT weapon and involves ground-based infrastructure at Plesetsk Cosmodrome near Noginsk-9, which was the location of the ground control center for the Soviet-era IS co-orbital ASAT and is near the headquarters for the Russian military space surveillance network. TsNIIKhM also supplied the explosive warhead for the Cold War-era IS co-orbital ASAT system. A separate project, Nivelir (“Dumpy level”) was also started in 2011 and is also managed by TsNIIKhM and appears to be aimed at developing inspection satellites using the same bus, thermal catalytic thrusters, and fuel tanks as the Burevestnik co-orbital ASATs. Nivelir may support the Burevestnik program either by testing RPO technology or providing tracking and targeting support. <sup>23</sup>

### Summary of Known or Suspected Russian Co-orbital-ASAT Tests in Space

Date	Interceptor	Launch Site	Target	Debris Created <sup>24</sup>	Result
Nov. 1963	Polyot 1	Baikonur	None	0	Engine and maneuvering test
Apr. 12, 1964	Polyot 2	Baikonur	None	0	Engine and maneuvering test
Oct. 27, 1967	Cosmos 185 (IS)	Baikonur	None	0	First test launch of IS interceptor
Oct. 20, 1968	Cosmos 249, Cosmos 252 (IS)	Baikonur	Cosmos 248	252	Attacked target twice: by Cosmos 249 on Oct 20 and by Cosmos 252 on Nov 1
Oct. 23, 1970	Cosmos 374, Cosmos 375 (IS)	Baikonur	Cosmos 373	147	Attacked target twice: by Cosmos 374 on Oct 23 & by Cosmos 375 on Nov 30
Feb. 25, 1971	Cosmos 397 (IS)	Baikonur	Cosmos 394	118	Successful ASAT test
Mar. 18, 1971	Cosmos 404 (IS)	Baikonur	Cosmos 400	0	Longer test flight with new approach from above to intercept target
Dec. 3, 1971	Cosmos 462 (IS)	Baikonur	Cosmos 459	28	Successful, created least amount of debris
Feb. 16, 1973	Cosmos 804, Cosmos 814 (IS)	Baikonur	Cosmos 803	0	Attacked target twice: by Cosmos 804 on Feb 16 & by Cosmos 814 on Apr 13
Jul. 9, 1976	Cosmos 839	Baikonur	Cosmos 839	0	Intercepted satellite but possible failure; de-orbited post launch
Dec. 17, 1976	Cosmos 886 (IS)	Baikonur	Cosmos 880	127	Intercepted target and successfully destroyed it
May 23, 1977	Cosmos 910, Cosmos 918 (IS)	Baikonur	Cosmos 909	0	Attacked target twice: by Cosmos 910 on May 23 & by Cosmos 918 on Jun 17 (both failures)

Date	Interceptor	Launch Site	Target	Debris Created <sup>24</sup>	Result
Oct. 26, 1977	Cosmos 961 (IS)	Baikonur	Cosmos 959	0	Successful ASAT test; interceptor de-orbited after using on-board engine
Dec. 21, 1977	Cosmos 970 (IS)	Baikonur	Cosmos 967	0	Missed target, used as target itself in following test
May 19, 1978	Cosmos 1009 (IS)	Baikonur	Cosmos 970	71	Successful ASAT test; interceptor self-destructed after
Apr. 18, 1980	Cosmos 1174 (IS)	Baikonur	Cosmos 1171	45	Failed ASAT test, interceptor missed target twice; Satellite self-destructed causing debris
Feb. 2, 1981	Cosmos 1243, Cosmos 1258 (IS)	Baikonur	Cosmos 1241	0	Attacked target twice: by Cosmos 1243 on Feb 2 & by Cosmos 1258 on Mar 14 (both failures)
Jun. 18, 1982	Cosmos 1379 (IS-P)	Baikonur	Cosmos 1375	63	Possibly successful ASAT test, deorbited using on-board engine
Nov. 20, 1990	Naryad-V	Baikonur	None	0	Suborbital test of the rocket and Briz upper stage
Dec. 20, 1991	Naryad-V	Baikonur	None	0	Suborbital test of the rocket and Briz upper stage
Dec. 26, 1994	Naryad-V	Baikonur	None	27	Potential stealth test, covered by launch of Radio-ROSTO; Naryad-V exploded in orbit
Aug. 23, 2017	Cosmos 2521	Plesetsk	None	0	Ejected another object (Cosmos 2523) at relatively high speed; no known target
Aug-Dec 2019	Cosmos 2536	Plesetsk	Cosmos 2535	30	RPO operations within 2 km and as far apart as 380 km; multiple ejections of debris at relatively high speeds, a possible test
Jul. 15, 2020	Cosmos 2543	Plesetsk	None	0	Ejected another object (Object 45915) at relatively high speed; no known target

## ENDNOTES

1. Bart Hendrickx, "Naryad-V and the Soviet Anti-Satellite Fleet," Space Chronicle, Vol 69, 2016, available at <http://www.bis-space.com/belgium/wp-content/uploads/2016/09/Naryad-V-and-the-Soviet-Anti-Satellite-Fleet.pdf>.
2. Anatoly Zak, "IS Anti-satellite System," Russian Space Web, last modified July 13, 2017, <http://www.russianspaceweb.com/is.htm>.
3. Data compiled from multiple sources and available here: [https://docs.google.com/spreadsheets/d/1e5GtZEzdo6xk41i2\\_ei3c8jRZDjvP4Xwz3BVsUHwi48/edit#gid=1252618705](https://docs.google.com/spreadsheets/d/1e5GtZEzdo6xk41i2_ei3c8jRZDjvP4Xwz3BVsUHwi48/edit#gid=1252618705).
4. Laura Grego, "A History of Anti-Satellite Programs," Union of Concerned Scientists, January 2012, <https://www.ucsusa.org/sites/default/files/legacy/assets/documents/nwgs/a-history-of-ASAT-programs-lo-res.pdf>.
5. Pavel Podvig, "Is China Repeating the Old Soviet and U.S. Mistakes?" Russian Strategic Nuclear Forces, January 19, 2007, [http://russianforces.org/blog/2007/01/is\\_china\\_repeating\\_the\\_old\\_sov.shtml](http://russianforces.org/blog/2007/01/is_china_repeating_the_old_sov.shtml); Bart Hendrickx, "Naryad-V and the Soviet Anti-Satellite Fleet," Space Chronicle, Vol 69, 2016, available at <https://www.readkong.com/page/naryad-v-and-the-soviet-anti-satellite-fleet-3671619>.
6. Pavel Podvig, "Did Star Wars Help End the Cold War? Soviet Response to the SDI Program," Russian Forces, March 17, 2013, [http://russianforces.org/blog/2013/03/did\\_star\\_wars\\_help\\_end\\_the\\_col.shtml](http://russianforces.org/blog/2013/03/did_star_wars_help_end_the_col.shtml).
7. Anatoly Zak, "UR-100," Russian Space Web, updated June 27, 2013, [http://www.russianspaceweb.com/baikonur\\_ur100.html](http://www.russianspaceweb.com/baikonur_ur100.html); "Rocket Launch Vehicles," updated December 24, 2019, <http://www.russianspaceweb.com/rocket.html>.
8. Mark Wade, "Radio," Astronautix, Accessed March 22, 2018, <http://www.astronautix.com/r/radio.html>; "Спутник 'Космос-2519' Минобороны РФ фотоаппарат сфотографирует [Sputnik 'Cosmos-2519' of the Russian Defense Ministry Will Photograph Space Objects]," Military News, June 22, 2017, <http://www.militarynews.ru/story.asp>.
9. "С запущенного в интересах Минобороны космического аппарата войдет в космос спутник-инспектор," Interfax.ru, August 23, 2017, <http://www.interfax.ru/russia/576068>.
10. "С запущенного в интересах Минобороны космического аппарата выведен в космос спутник-инспектор," Interfax.ru, August 23, 2017, <http://www.interfax.ru/russia/576068>.
11. "Российский военный спутник-инспектор проверил другой космический аппарат России на орбите," TASS, August 1, 2019, <https://tass.ru/kosmos/6724059>; Jonathan McDowell, "Space Activities in 2019," January 12, 2020, pp. 25-28, <https://planet4589.org/space/papers/space19.pdf>.
12. Министерство обороны Российской Федерации, «С космического аппарата, запущенного в интересах Минобороны 23 июня, выведен в космос малый спутник-инспектор», August 23, 2017, [https://function.mil.ru/news\\_page/country/more.htm?id=12193523@egNews](https://function.mil.ru/news_page/country/more.htm?id=12193523@egNews).
13. W.J. Hennigan, "Exclusive: Strange Russian Spacecraft Shadowing U.S. Space Satellite, General Says," Time.com, February 10, 2020, <https://time.com/5779315/russian-spacecraftspy-satellite-space-force/>.
14. Nathan Strout, "Russia conducted anti-satellite test in space; says US Space Command," DefenseNews, July 23, 2020, <https://www.defensenews.com/battlefield-tech/space/2020/07/23/russia-conducted-anti-satellite-test-in-space-says-us-space-command>.
15. "Успешный пуск ракетно-носителя 'Союз-2.16,'" TASS, November 26, 2019, <https://www.roskosmos.ru/27793/>; "Минобороны провело в космосе эксперимент по отделению малого спутника от другого аппарата," TASS, December 6, 2019, <https://tass.ru/armiya-i-opk/7285111>.
16. Jonathan McDowell, "Space Activities in 2019," January 12, 2020, pg. 29, <https://planet4589.org/space/papers/space19.pdf>.
17. Initial observations and analysis were developed by multiple observers on the See-Sat mailing list as documented here <http://www.satobs.org/seesat/Dec-2019/0108.html>. Additional analysis provided by Michael Thompson in a tweet thread posted January 30, 2020, [https://twitter.com/M\\_R\\_Thompson/status/1222991026650964998](https://twitter.com/M_R_Thompson/status/1222991026650964998). Further analysis by Jonathan McDowell in a tweet thread posted February 1, 2020, <https://twitter.com/planet4589/status/1223420130576818176?s=20>.

18. USSPACECOM Public Affairs Office, "Russia conducts space-based anti-satellite weapons test," United States Space Command, July 23, 2020, <https://www.spacecom.mil/Newsroom/News/Article-Display/Article/2285098/russia-conducts-space-based-anti-satellite-weapons-test/>.
19. "Российский военный спутник-инспектор проверил другой космический аппарат России на орбите," TASS, August 1, 2019, <https://tass.ru/kosmos/6724059>.
20. Jonathan McDowell (2019), pp. 25-28.
21. Data compiled from the public catalog maintained by the U.S. military at <https://Space-Track.org>.
22. Bart Hendrickx, "Burevestnik: A Russian Air-launched Anti-satellite System," The Space Review, April 27, 2020, <http://www.thespacereview.com/article/3931/1>.
23. Bart Hendrickx, posting on the NASASpaceflight.com forums, February 1, 2019, <https://forum.nasaspaceflight.com/index.php?topic=43064.msg1590977#msg1590977>
24. Data compiled from the public catalog maintained by the U.S. military at <https://Space-Track.org>.



525 Zang Street, STE. D  
Broomfield, CO 80021 USA  
v: + 1 303 554 1560

1779 Massachusetts Ave. NW  
Washington, DC 20036 USA  
v: + 1 202 568 6212

e: [info@swfound.org](mailto:info@swfound.org)